

HENSEL
PERFORMING LIGHT

VISIT
INDUSTRIAL LIGHT

Continuous light Intra LED



User manual

Translation of the original German user manual

Doc. no. 900.0526.00

Version: 01/2019

Contents

Information about this manual and about the manufacturer	4
Keeping this manual on hand	4
Design features in the text	4
Design features in the figures	5
Copyright	5
Manufacturer's address.....	5
Safety	6
Intended use	6
Fundamental safety information	6
Prevention of equipment damage and malfunctions.....	7
Design features of warning notices	8
Design features of equipment or property damage information.....	8
Warning and information sign	9
Description	10
Overview of scope of delivery	10
Overview of device front	11
Controls	12
Overview of swivel head.....	13
Task and function	14
Type plate	15
Technical data.....	16
Unpacking the device and checking the scope of delivery	17
Commissioning the device.....	18
Mounting and removing components of the device	19
Removing and installing the transport cap.....	19
Installing and removing the protection glass	21
Mounting the light shaping tool on/removing it from the device.....	22
Connecting and disconnecting the mains cable	25
Mounting the device on/removing it from a stand	26

Rotating and tilting the device	27
Mounting the device on/removing it from a pantograph	29
Mounting the umbrella on/removing it from the device	32
Operating the device	33
Activating and deactivating the device	33
Adjusting the energy	34
Error messages	35
Transporting and storing the device.....	36
Servicing the device.....	37
Caring for and cleaning the device	37
Replacing a defective protection glass	38
Replacing a defective fuse of the mains connection	39
Disposing of the device and packaging	40
In Germany	40
Outside of Germany	40
Accessories.....	41
Warranty provisions	42
In Germany	42
Outside of Germany	42
Limitation of liability	43
Returning a product to Customer Service	44

Information about this manual and about the manufacturer

This manual can assist you with safe use of the “Intra LED” continuous light. In the following text, the “Intra LED” continuous light is called “device” for short.

Keeping this manual on hand

This manual is part of the device.

- Always keep this manual together with the device.
- Provide this manual when selling the device or passing it on in another manner.

Design features in the text

Various elements of this manual are provided with specific design features. This allows you to easily differentiate between the following elements:

Normal text

- Action
- Bullet points
- ⓘ Tips contain additional information, e.g. special information on the device.

Design features in the figures

If elements are referred to in a key or in the body text, then they are provided with a number (1).

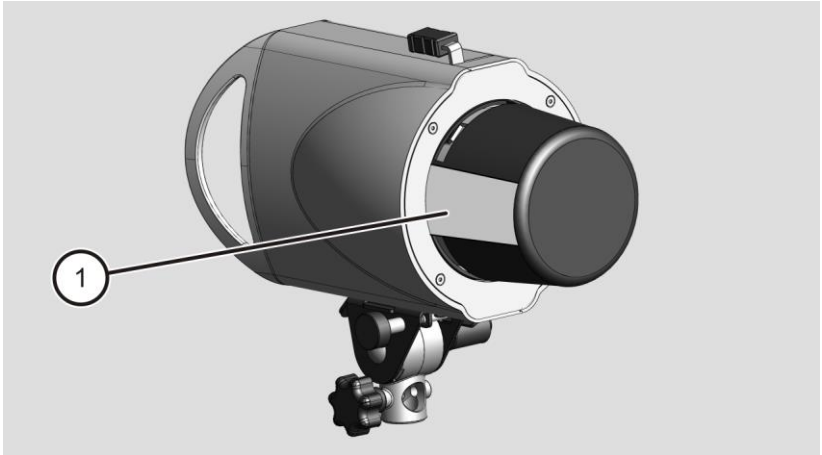

Copyright

This manual contains information that is subject to copyright. Without the prior written permission of Hensel-Visit GmbH & Co. KG, this manual shall not be copied, printed, filmed, processed, reproduced or distributed in any form, in full or in excerpts.

©Hensel-Visit GmbH & Co. KG
All rights reserved.

Manufacturer's address

Hensel-Visit GmbH & Co. KG
Robert-Bunsen-Str. 3
97076 Würzburg
Phone: +49-931-27881-0
Fax: +49-931-27881-50
E-mail: info@hensel.de
URL: www.hensel.de

Safety

The device has been built according to state-of-the-art technology and recognized safety-related regulations. During work with and on the device, however, residual risk remains, which could present a danger to life and limb. For this reason, the following safety information is to be observed and followed.

Intended use

The device is designed to provide illumination for indoor photography and videography.

The intended use also includes reading and understanding this manual, as well as observing and following all information in this manual, especially the safety information. In addition, the safety information and all other instructions in the manuals of the cameras used must also be noted and observed. Any other use is expressly considered as unintended and will invalidate any warranty or liability claims.

Fundamental safety information

Prevention of serious injuries or death from electric shock

Improper work on the device can lead to an electric shock.

- Only connect the device to a power mains with an intact protective conductor.
- Only use plugs with contacts in perfect condition.
- Protect the device from moisture.
- Never use a wet device.
- Do not open the housing.
- Where possible, avoid laying the cable on the ground. If laying on the ground cannot be avoided, make sure the cables are not damaged by vehicles or ladders.
- Regularly clean the outside of the device with a dry cloth.
- Have damaged cables and the device replaced immediately by the authorized customer service only.

Prevention of the risk of burns

The device generates heat during operation. If the ventilation slots are covered, this can heat up the device, possibly leading to burn injuries if the device is touched.

- Make sure the ventilation slots are not covered during operation.

Prevention of equipment damage and malfunctions

Prevention of equipment damage due to fogging

Fogging can occur due to a sudden temperature change, e.g. in a new environment.

- Always let the device acclimatize before use in a new environment.

Prevention of equipment damage due to rain, vapors, frost, heat, humidity and dust

Rain, vapors, frost, heat, humidity and dust can damage the device.

- Protect the device from dripping and spraying water (e.g. rain) or vapors.
- Protect the device from frost, heat and high humidity.
- Do not place containers of liquids on the device.
- Make sure that neither the device nor its components are standing or lying on wet ground.
- Do not store the device in locations exposed to heat or moisture.
- Cover the device with suitable dust protection when it is not in operation.



Prevention of equipment damage when using external products

The use of the device in combination with external products can lead to equipment damage.

- Use the device only with accessories and original spare parts recommended by the manufacturer.

Design features of warning notices

This user manual contains the following safety information:

⚠ WARNING	
	Messages with the word WARNING warn about a dangerous situation that could lead to death or serious injuries.
⚠ CAUTION	
	Notices with the word CAUTION warn about a situation that could lead to light or medium-scale injuries.

Design features of equipment or property damage information

IMPORTANT!	
	This information warns against a situation that can lead to equipment or property damage.

Warning and information sign

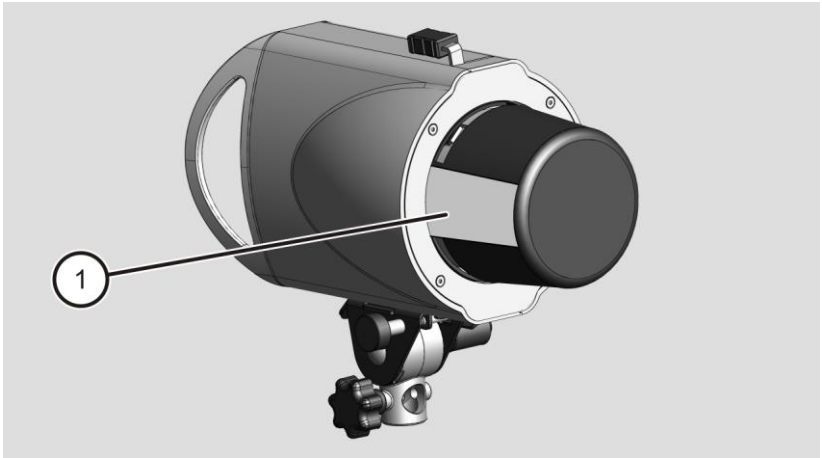

No.	Explanation
1	Remove the transport cap before commissioning

Description

Overview of scope of delivery

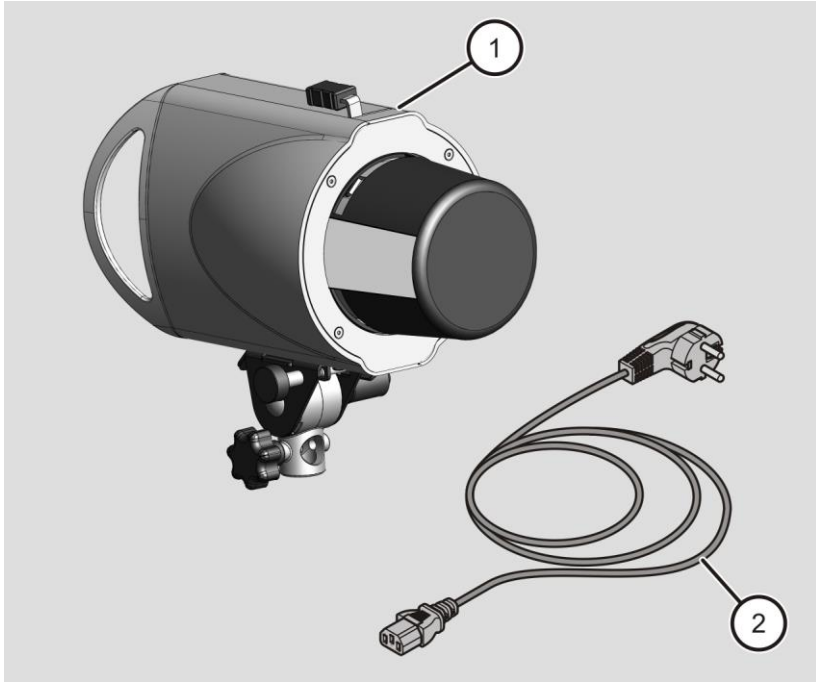

No.	Designation
1	Device
2	Mains cable (country-specific, example picture)

Overview of device front

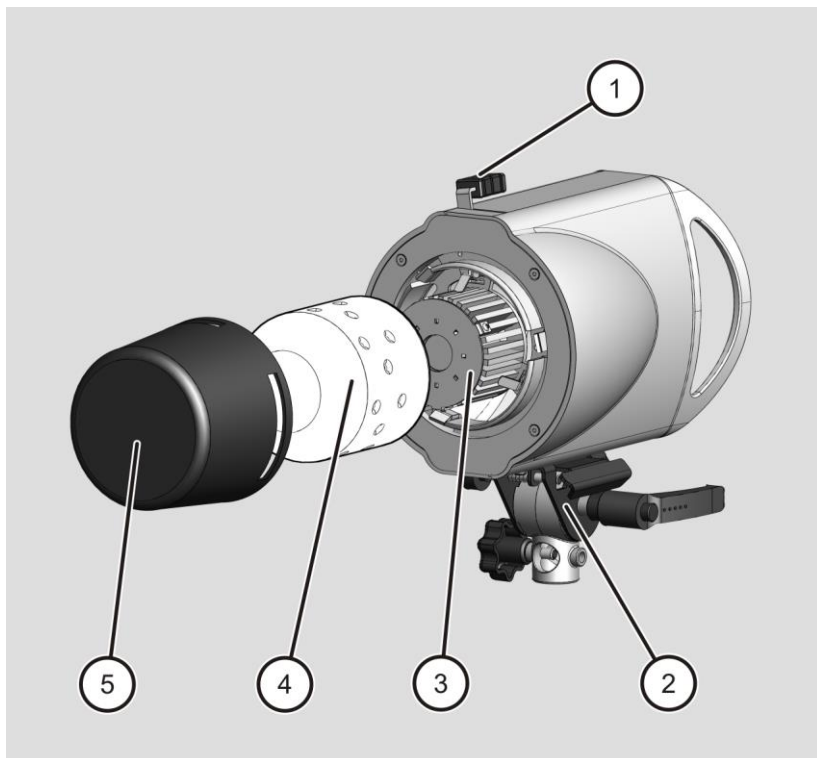

No.	Designation
1	Lock of the holder for the light shaping tool and transport cap
2	Swivel head
3	LED illuminant with cover
4	Protection glass
5	Transport cap

Controls

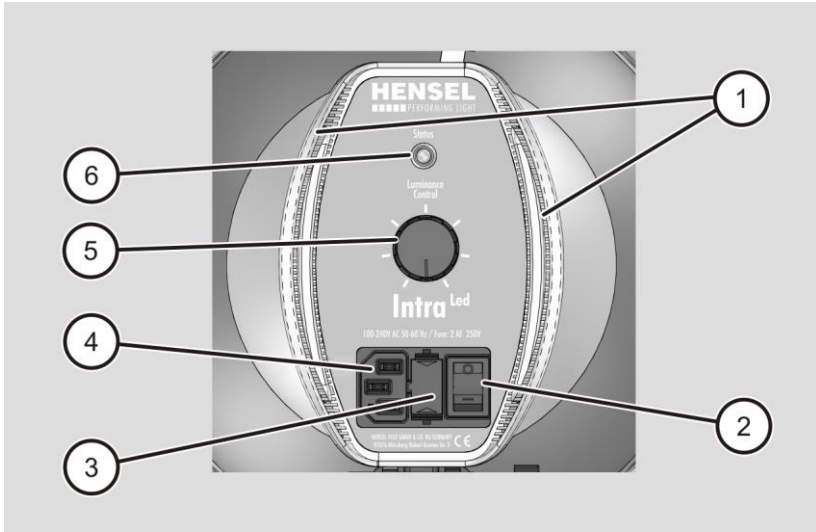

No.	Designation
1	Handles
2	Main switch: Activating and deactivating the device
3	Fuse holder for mains socket
4	Mains socket
5	Rotary switch for adjusting energy
6	Status LED: lights up green during operation and red for error warnings

Overview of swivel head

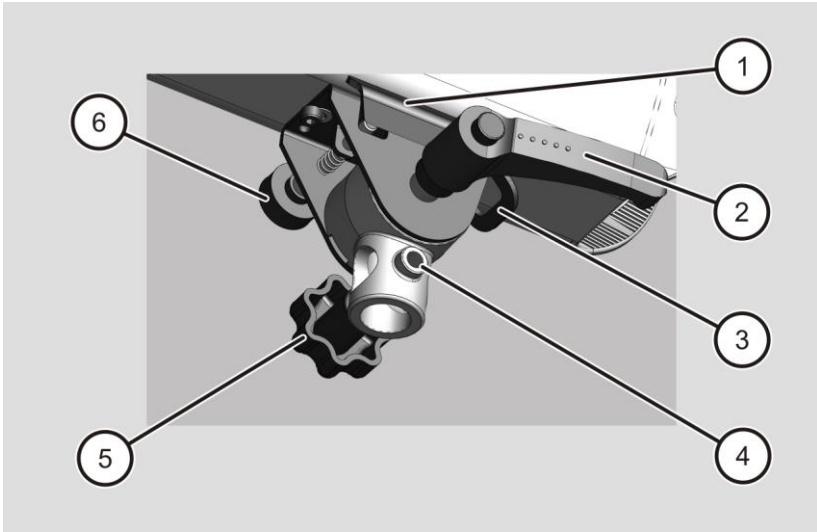

No.	Designation
1	Umbrella holder
2	Locking lever
3	Hanger clip for safety rope
4	Thread for locking screw
5	Knurled screw for stand adapter
6	Knurled screw for umbrella holder

Task and function

The device is designed to provide illumination for indoor photography and videography. It can be operated on the mains and attached to a stand or a pantograph.

The device has an LED output of 50 W. Using the rotary switch, the energy can be adjusted across an energy range from 10 %–100 %. Swapping the light shaping tool offers further options to change the quality of the lighting.

The color temperature is 5000 K and cannot be changed.

Type plate

The type plate is attached to the housing. You will find the following information on the type plate:

- Manufacturer name
- Name of the model
- Code number
- CE marking
- Symbol for environmentally sound disposal
- Country of manufacturing

Technical data

Device type	Intra LED
Article number	8710
Energy range	10 %–100 %
Illuminant	50 W LED
Light intensity	3600 lx/335 fc (9" light shaping tool from 1 m distance) 1700 lx/158 fc (60 × 60 cm softbox from 1 m distance)
Weight	approx. 1.45 kg
Dimensions (L x H x W in mm)	260 × 210 × 140
Voltage range	100–240 V/50 & 60 Hz
Color rendering	CRI 92
Color temperature	5000 K
Fuses	2.5 AF/250 V
Mains socket	100–240 V~, 50/60 Hz
Light shaping tool connector	Hensel EH (10 cm)
Umbrella holder	integrated
Power consumption	max. 0.9 A at 110 V and 0.5 A at 230 V
Cooling	yes
Fan	continuous operation
Control element	rotary switch
Subject to technical change. The specified data constitutes typical values that can be subject to fluctuations due to the tolerances of the components used.	

Unpacking the device and checking the scope of delivery

- Remove the device from the packaging.
- Keep the original packaging in case you need to return the product to Customer Service.
- Check the scope of delivery for correctness and completeness (see page 10).
- Ensure that all parts are undamaged.
- If any parts are incorrect or missing, contact the manufacturer and/or dealer immediately.

Commissioning the device

To commission the device, proceed as follows:

- Remove the transport cap (see page 19).
- Make sure the protection glass is installed.
- Mount the light shaping tool (see page 22).
- Connect the mains cable (see page 25).
- Turn on the device using the main switch (see page 33).

Mounting and removing components of the device

IMPORTANT!

- The device can be damaged if external products are used.
- Use only original spare parts and accessories from the manufacturer.

Removing and installing the transport cap

⚠ WARNING



- Heat is generated during the operation of the device, which can lead to a fire if the transport cap is in place.
- Always remove the transport cap before use.

To remove the transport cap from the device, proceed as follows:

- Hold the transport cap (3) firmly.
- Press the lock on the device (1) to the stop against the spring force.
- Remove the transport cap (3).
- Guide the lock (1) into the starting position using the spring force.

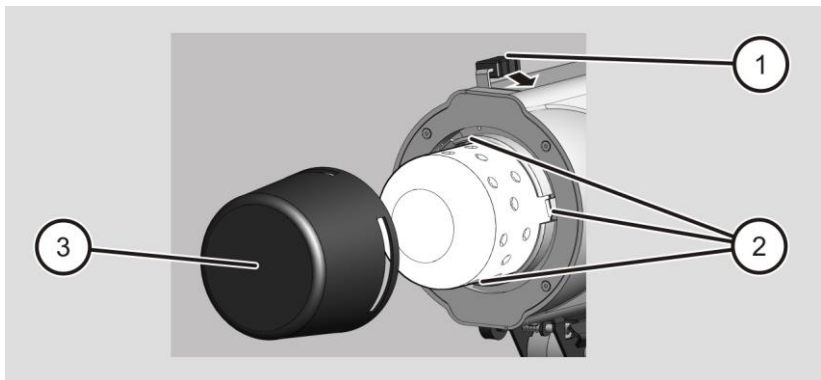

To install the transport cap, proceed as follows:

- Press the lock (1) against the spring force to the limit stop.
- Place the transport cap (3) on the device in such a manner that the three mounting claws (2) are inside the transport cap (3) and engage in the openings.
- Hold the transport cap (3) firmly while guiding the lock (1) into the starting position using the spring force.
- Make sure the transport cap (3) is seated correctly.

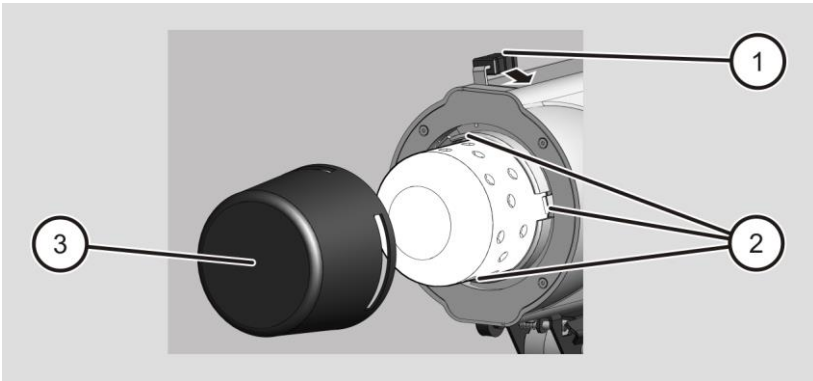

Installing and removing the protection glass

WARNING



Heat is generated during the operation of the device. Touching the device at the front can lead to severe burns.

- Always let the device cool down for 5 to 10 minutes before mounting or removing components.

To install the protection glass (1), proceed as follows:

- Wear gloves according to EN 407.
- Tilt the protection glass (1) slightly and insert it into one of the three springs (2).
- Insert the protection glass (1) into the second spring (2) using slight pressure.
- Press the protection glass (1) into the third spring (2) until it engages securely.

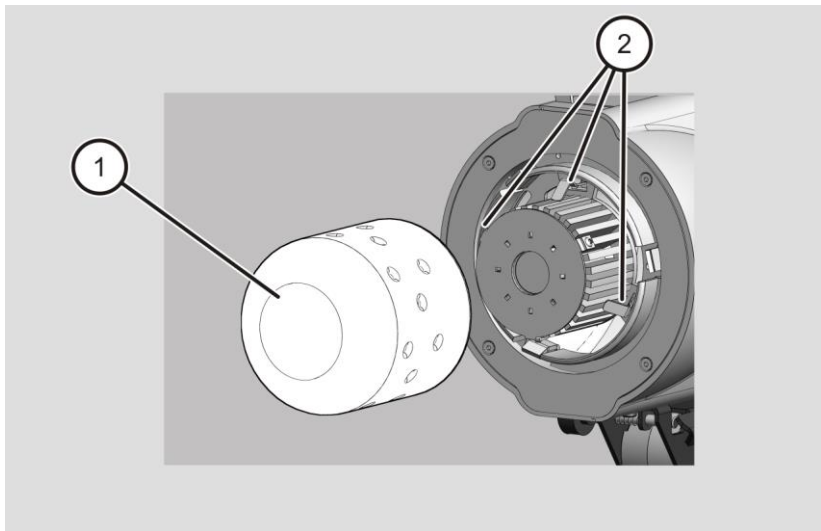

To remove the protection glass (1), proceed as follows:

- Tilt the protection glass (1) slightly and so that it disengages from two of the three springs (2) one after the other.
- Release the protection glass (1) from the third spring (2) by pulling it slightly and remove it.

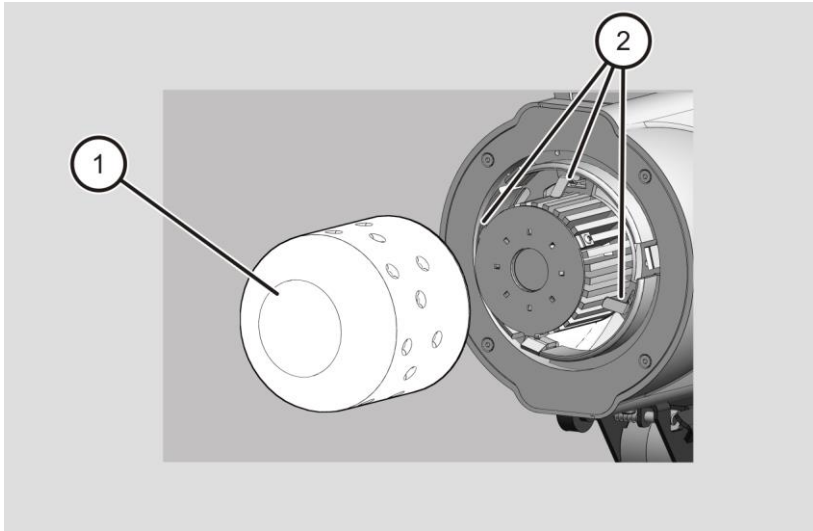

Mounting the light shaping tool on/removing it from the device

WARNING



Heat is generated during the operation of the device. Touching the device at the front can lead to severe burns.

- Always let the device cool down for 5 to 10 minutes before mounting or removing components.

IMPORTANT!

When mounting or removing the light shaping tool on and from the device, the protection glass can be damaged.

- Do not touch the protection glass with the light shaping tool.
- Make sure the device is held firmly when mounting and removing the light shaping tool.
- When mounting the light shaping tool, place it evenly onto the device.
- When mounting and removing the light shaping tool, hold it firmly with one hand.

To mount the light shaping tool onto the device, proceed as follows:

- Press the lock (1) against the spring force to the limit stop.
- Place the light shaping tool (3) on the device in such a manner that the three mounting claws (2) are inside the light shaping tool (3).
- Hold the light shaping tool (3) firmly while guiding the lock (1) into the starting position using the spring force.
- Make sure the light shaping tool (3) is seated correctly.

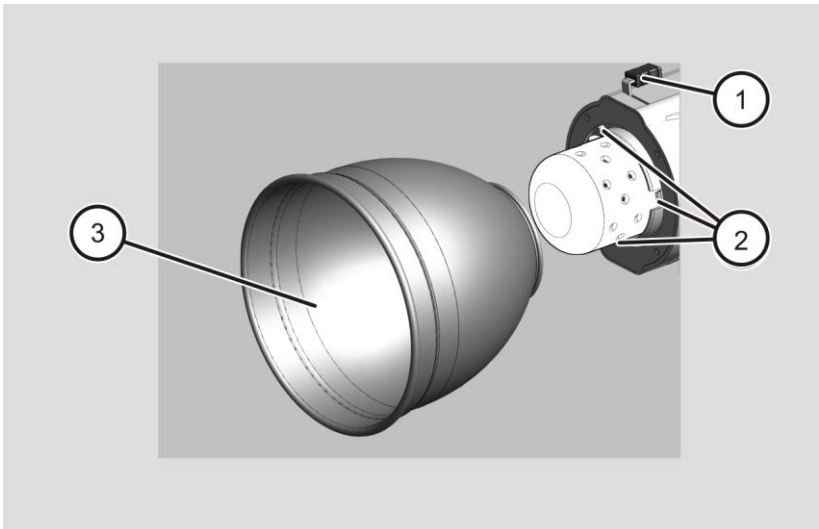

To remove the light shaping tool, proceed as follows:

- Hold the light shaping tool (3) firmly in one hand.
- With the other hand, press the lock (1) to the stop against the spring force.

The light shaping tool will be released from the three mounting claws (2).

- Remove the light shaping tool (3) from the device and set it aside.
- Guide the lock (1) into the starting position again using the spring force.

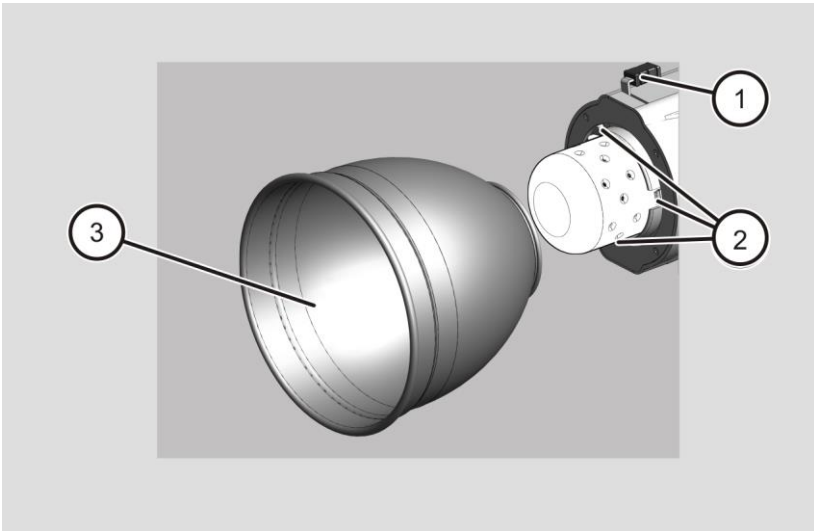

Connecting and disconnecting the mains cable

To connect the mains cable, proceed as follows:

- Insert the plug of the mains cable into the mains socket (1) of the device.
- Connect the mains cable to a mains outlet.

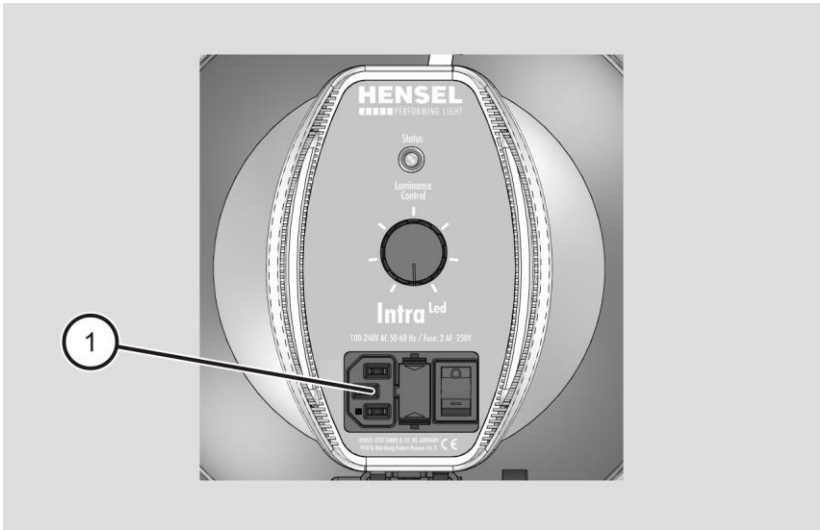

To remove the mains cable from the device, proceed as follows:

- Remove the mains cable from the mains socket.
- Remove the plug of the mains cable from the mains socket (1) of the device.

Mounting the device on/removing it from a stand

To mount the device on a stand, proceed as follows:

- Loosen the knurled screw (1).
- Make sure that you do not completely unscrew the knurled screw (1).
- Place the device on the stand (2) and tighten the knurled screw (1).

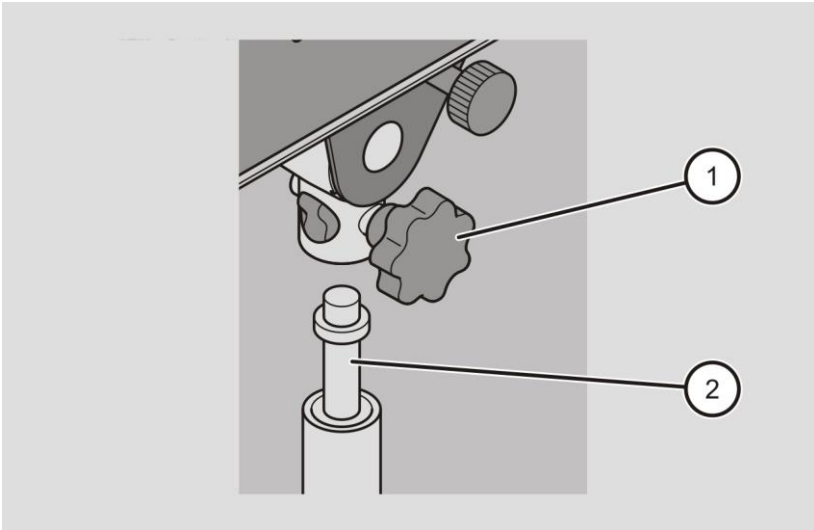

To remove the device from the stand, proceed as follows:

- Loosen the knurled screw (1).
- Remove the device from the stand (2).

Rotating and tilting the device

⚠ CAUTION



Crushing injuries can occur when loosening the locking lever.

- To prevent twisting and tipping over, hold the device firmly with one hand while loosening the locking lever with the other.

When mounting the device onto a stand or pantograph, the device can be rotated horizontally by 360° and tilted vertically by approx. 180°.

- To rotate the device horizontally, loosen the knurled screw (1).
- Rotate the device into the desired position and tighten the knurled screw (1).

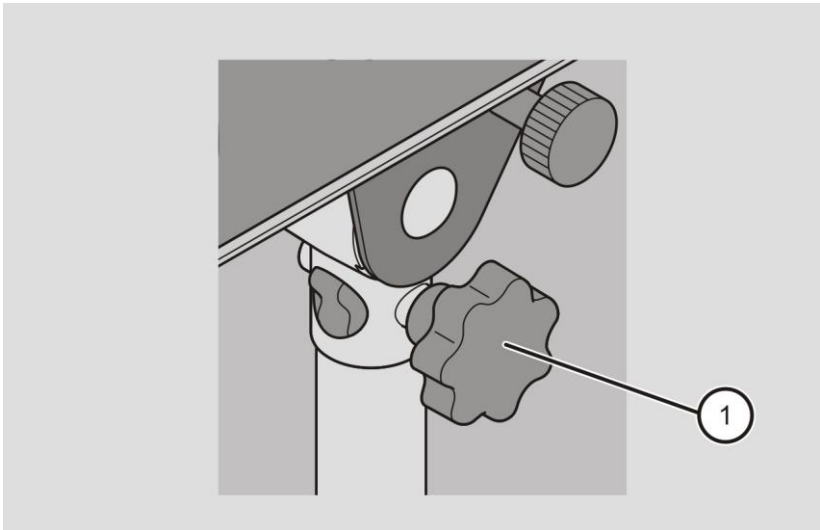

- To tilt the device vertically, loosen the locking lever (1).
- Pivot the device into the desired position and tighten the locking lever (1).

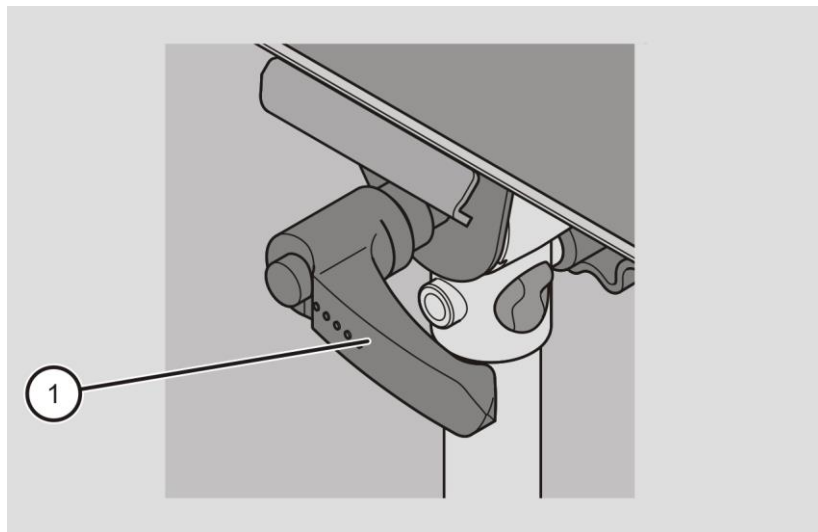

Mounting the device on/removing it from a pantograph

WARNING



If the device is attached to a pantograph, the mounting can become loose and the device can fall, potentially leading to injuries.

- Secure the device with an additional locking screw (M6 x 16).
- Secure the device with the safety rope (see “Accessories”, page 41).

The device can be mounted on a pantograph, boom or telescopic boom. The mounting of the device on/removal of the device from a stay arm is described below.

To mount the device on a pantograph, proceed as follows:

- Loosen the knurled screw (2) without unscrewing it completely.
- Guide the device onto the spigot of the pantograph (3).
- Screw the locking screw (1) into the opening on the other side of the swivel head and tighten it so that it is hand-tight.

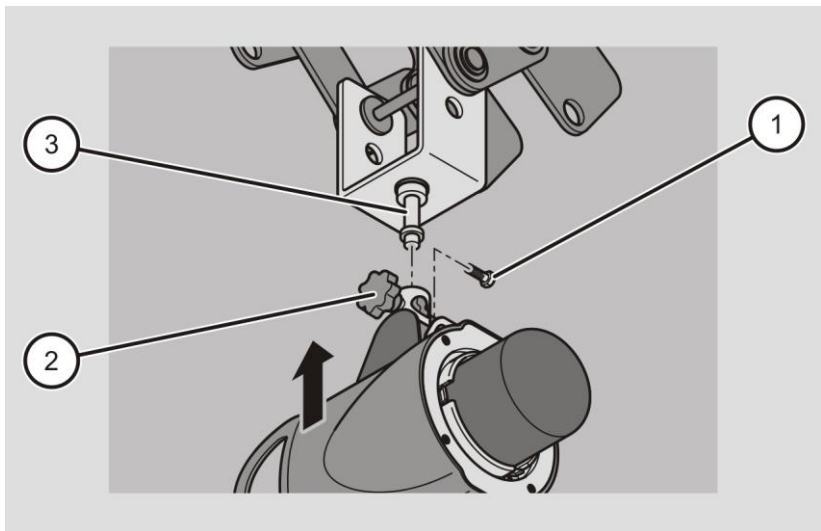

- Guide the safety rope (1) through a suitable and stable opening in the stay arm as seen in the following figure.
- Open the screw hook (4).
- Insert the rope thimble (3) into the screw hook (4).
- Insert the screw hook into the hanger clip (2).
- Close the screw hook (4) tightly again.

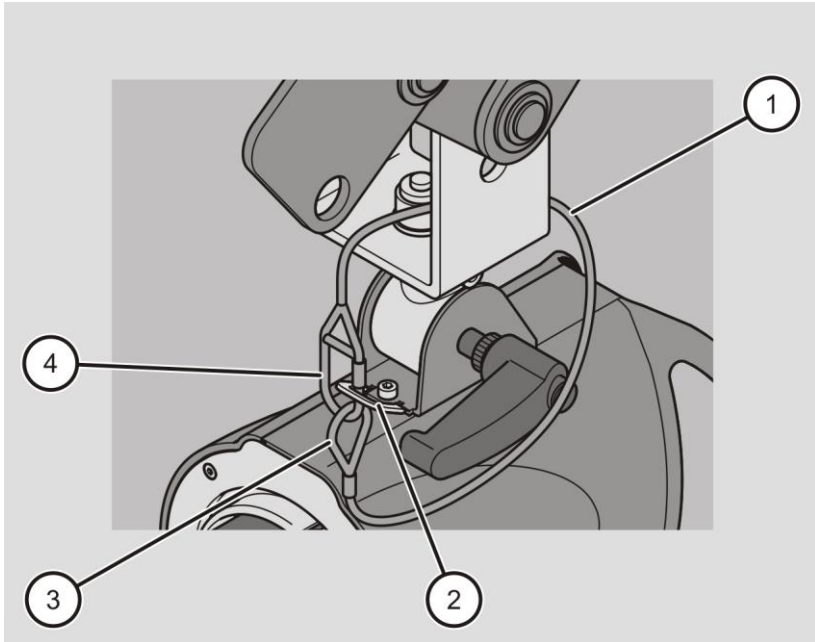

- ⓘ When working with a boom or telescopic boom, you can just wrap the safety rope several times around the tube of the boom or telescopic boom and fasten it to the device as described above.

To remove the device, proceed as follows:

- Open the screw hook (4).
- Remove the screw hook (4) from the hanger clip (2).
- Remove the rope thimble (3) from the screw hook (4).
- Remove the safety rope (1) from the opening of the pantograph.

- Loosen the locking screw (1).
- Loosen the knurled screw (2).
- Remove the device from the spigot of the stay arm (3).

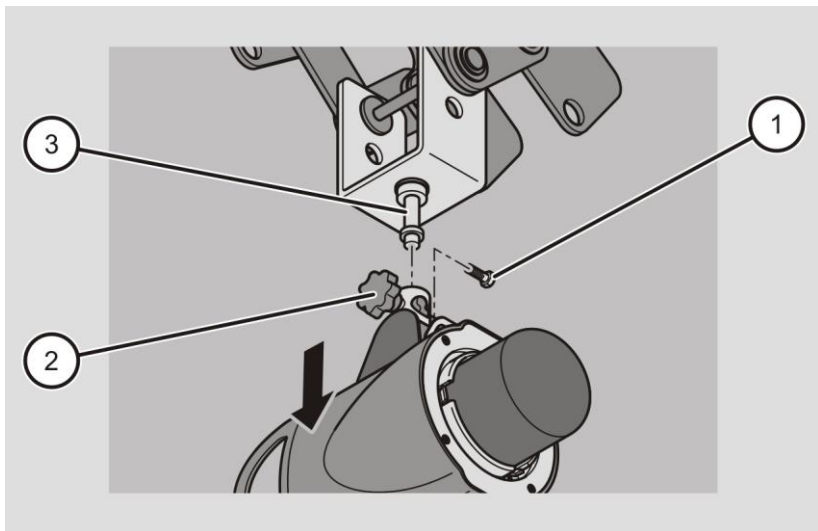

Mounting the umbrella on/removing it from the device

To mount the umbrella on the device, proceed as follows:

- Loosen the knurled screw (2).
- Make sure that you do not completely unscrew the knurled screw (2).
- Push the umbrella rod (3) into the umbrella holder (1).
- Tighten the knurled screw (2).

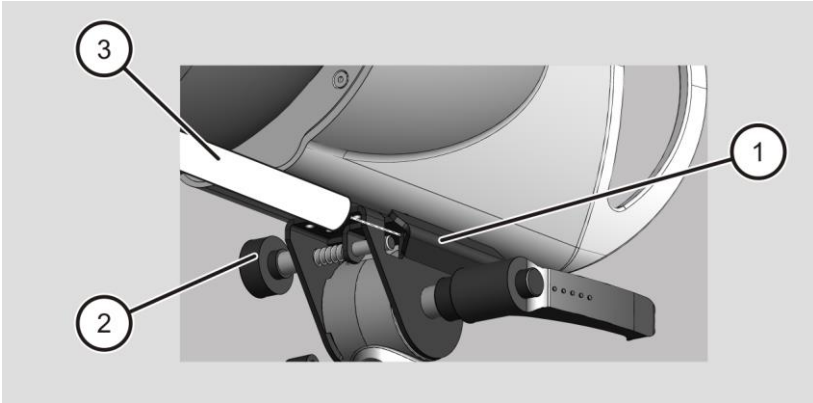

To remove the umbrella, proceed as follows:

- Hold the umbrella firmly with one hand.
- Loosen the knurled screw (2).
- Make sure that you do not completely unscrew the knurled screw (2).
- Pull the umbrella out of the umbrella holder (1).
- Tighten the knurled screw (2) again.

Operating the device

Activating and deactivating the device

- Make sure the mains voltage is between 100 V and 240 V, 50 & 60 Hz.
- Make sure the device is connected.
- To switch on the device, set the main switch (1) to the “I” position.
- To deactivate the device, set the main switch (1) to the “0” position.

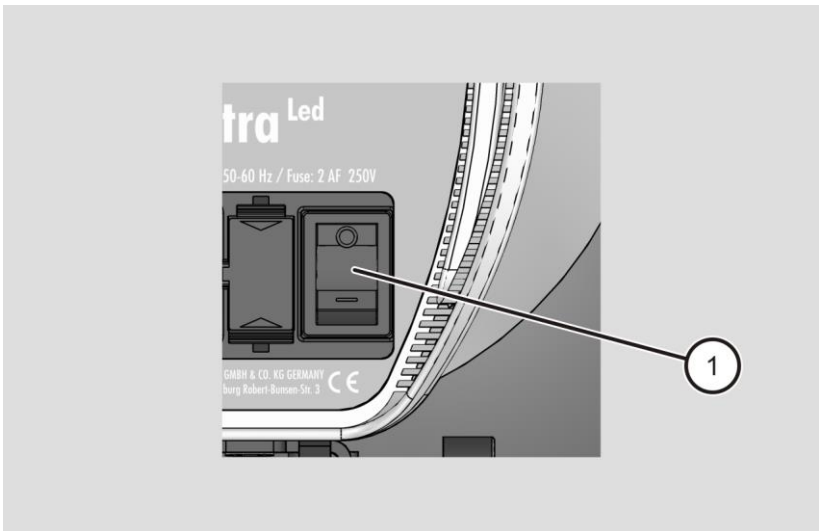

Adjusting the energy

The device energy can be set freely between 10% and 100%. To adjust it, proceed as follows:

- Make sure the device is activated.
- To increase the energy level, turn the rotary switch (1) clockwise.
- To decrease the energy level, turn the rotary switch (1) counter-clockwise.

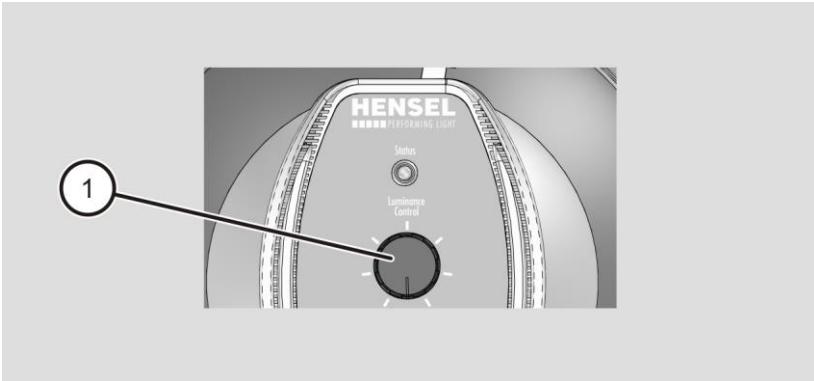

- i** The device fan makes a low sound when running. This sound is audible at close quarters and may interfere with live audio recordings. For live audio recordings, always ensure that the microphone is positioned some distance away from the device.
- i** The 9" metal light shaping tool is ideal for maximum luminous efficacy at an even light distribution.
- i** The use of large metal light shaping tools may increase operating noise. Softboxes, on the other hand, reduce operating noise and are well suited both for short subject distances and due to their lighting characteristics.

Error messages

Problem	Possible cause(s)	Remedy
LED lights up red: Temperature error	Over heating	The thermal switch deactivates the device to protect the LED. The fan keeps running and the device reactivates once it has sufficiently cooled down.
LED lights up red during operation:	Internal device error	<ul style="list-style-type: none"> ➤ Deactivate the device immediately. ➤ If the status LED still lights up red after reactivation, please send the device to customer service.



Transporting and storing the device

To transport and store the device, proceed as follows:

- Turn off the device at the main switch (see page 33).
- Remove the mains cable from the power mains.
- Remove the mains cable from the device (see page 25).
- Do not store the device in locations exposed to heat, moisture, frost or cold.
- Cover the device.

Servicing the device

Caring for and cleaning the device

 WARNING	
	<p>Heat is generated during the operation of the device. Touching the device at the front can lead to severe burns.</p> <ul style="list-style-type: none"> ➤ Let the device cool down for 5 to 15 minutes before cleaning.

To guarantee electrical safety, the device must be cleaned regularly. To clean it, proceed as follows.

- Regularly clean the outside of the device with a dry cloth.

Regular inspection

National safety regulations – e.g. the Industrial Safety Act (BetrSichV) and DGUV Regulation 3 (formerly BGV A3) in Germany – require inspection and maintenance of electrical devices at regular intervals. The operating safety of devices and accessories must be checked regularly. An annual inspection of the devices should be carried out for the safety of the users and to retain the value of the device.

The regulations specified above (BetrSichV and DGUV Regulation 3 (formerly BGV A3) apply to Germany; please observe the corresponding local regulations in your country.

Maintenance schedule

- Regularly clean the device as described in the “Caring for and cleaning the device” section above.
- Grease the thread of the knurled screw for the stand adapter every 1-2 years.

Maintenance	Time period
Check the operating safety of the device	Every 12 months
Check the operating safety of accessories	Every 12 months

Replacing a defective protection glass

WARNING



Heat is generated during the operation of the device.
Touching the device at the front can lead to severe burns.

- Always let the device cool down for 5 to 10 minutes before mounting or removing components.

To replace the protection glass, proceed as follows:

- Turn off the device at the main switch (see page 33).
- Remove the mains cable (see page 25).
- Remove the light shaping tool (see page 22).
- Remove the defective protection glass (see page 21).
- Mount the new protection glass (see page 21).
- Mount the light shaping tool (see page 22).
- Connect the mains cable (see page 25).
- Turn on the device at the main switch (see page 33).

Replacing a defective fuse of the mains connection

To replace the defective fuse, proceed as follows:

- Switch off the device at the main switch (1).
- Remove the mains cable (see page25).
- Open the fuse holder (2) with a small screwdriver or similar tool and pull it out.

The fuse holder (2) contains two fuses: the blown fuse and the spare fuse.

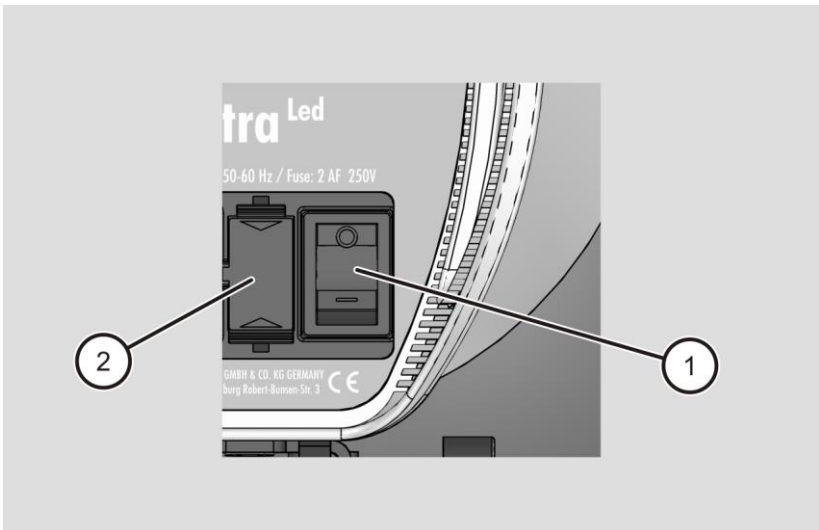

- Remove the blown fuse.
- Insert the spare fuse into the fuse holder (2).
- Carefully push the fuse holder (2) into the housing again until it snaps into place and is flush with the device surface.

i Remember to insert a new spare fuse as soon as possible.

Disposing of the device and packaging

In Germany

- Dispose of the packaging of the device, separated according to material. Use local options for collecting paper, cardboard and lightweight packaging.
- Dispose of the device and accessories separately from domestic waste. Information regarding collection points that accept old devices free of charge can be obtained from your municipal authority.



Outside of Germany

- Dispose of the device and packaging according to the regulations at the place of use.

Accessories

Designation	Article number
Protection glass, matt, for Intra LED	9454663
Transport cap, plastic	9456311
Mains cable, replacement	121
Safety rope	7690

Warranty provisions

In Germany

The warranty provisions can be found in our general terms and conditions for business on our website: www.hensel.de

Outside of Germany

The warranty provisions of the dealer from which you have purchased the device apply.

Limitation of liability

We are not liable for equipment or property damage, or personal injury arising from improper use of the device that is inconsistent with the information provided in the user manual. We are also not liable for consequential damages (such as production or income losses, etc.) that may be caused by a defect in or malfunction of our device.

Returning a product to Customer Service

As soon as you discover damage to the device, proceed as follows:

- Send the device in its original packaging with a precise description of the defect to the following address for repair:

HENSEL-VISIT GmbH & Co. KG
Customer Service Department
Robert-Bunsen-Str. 3
D-97076 Würzburg, Germany

Phone: +49 (0) 931-27881-0

Our Customer Service addresses within and outside of Germany can be found at:

www.hensel.de

